

11. BLOCK DIAGRAM

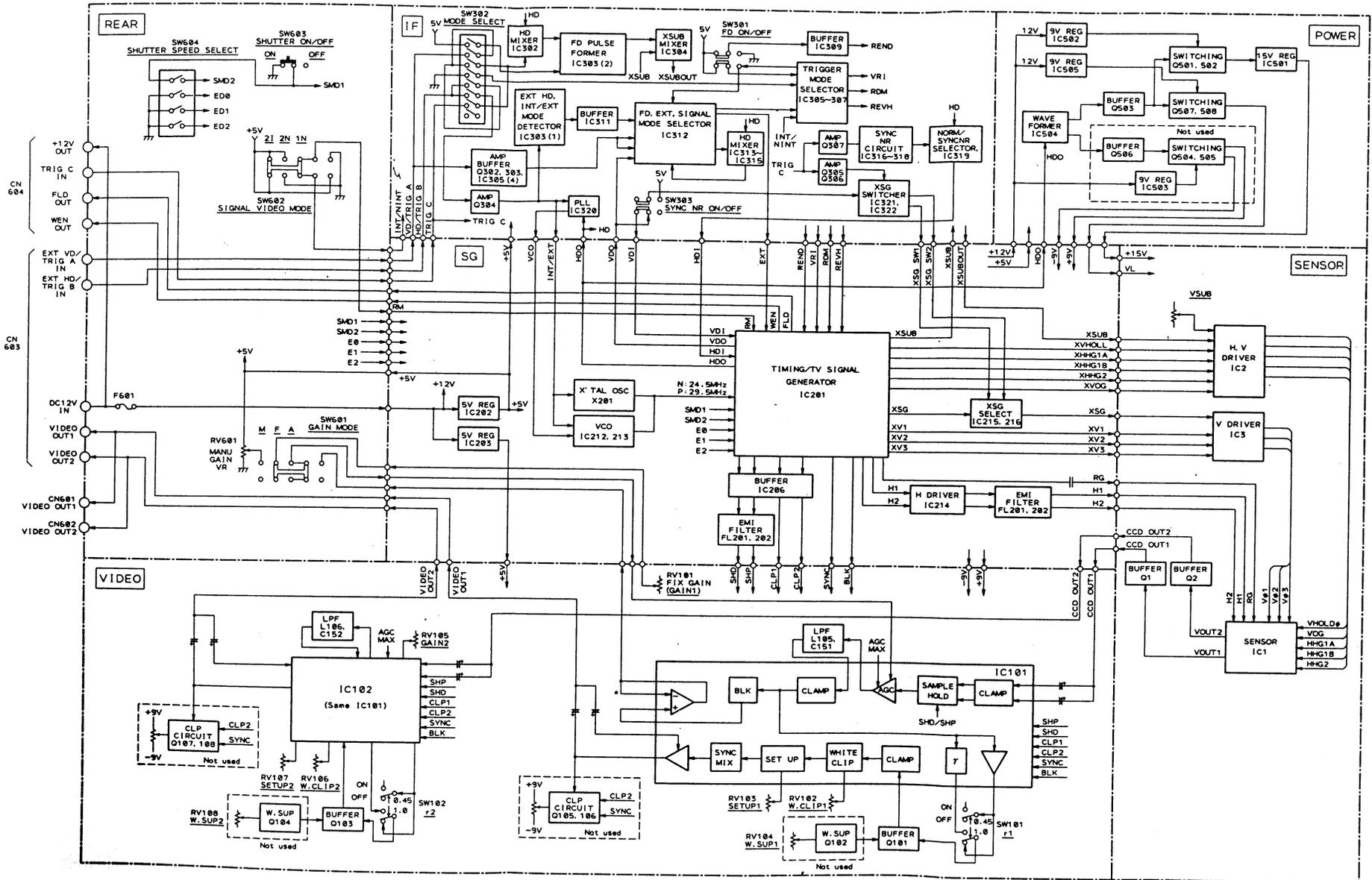

KP-F1
BLOCK DIAGRAM

12. SCHEMATIC DIAGRAM

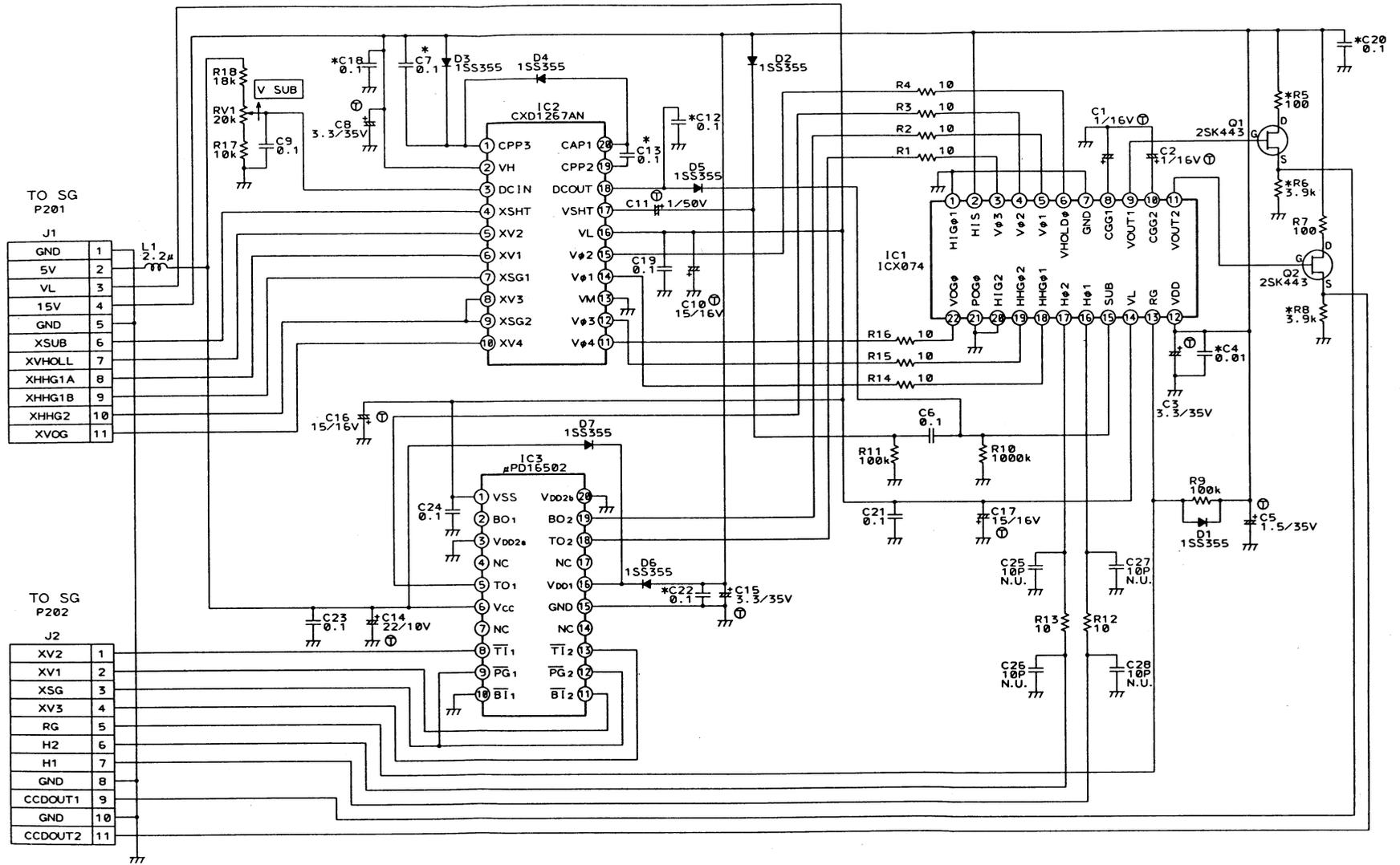

NOTE: Chip parts (R, C)
 NO Mark: 1608 TYPE
 *: 2125 TYPE

**KP-F1
 SENSOR
 SCHEMATIC DIAGRAM**

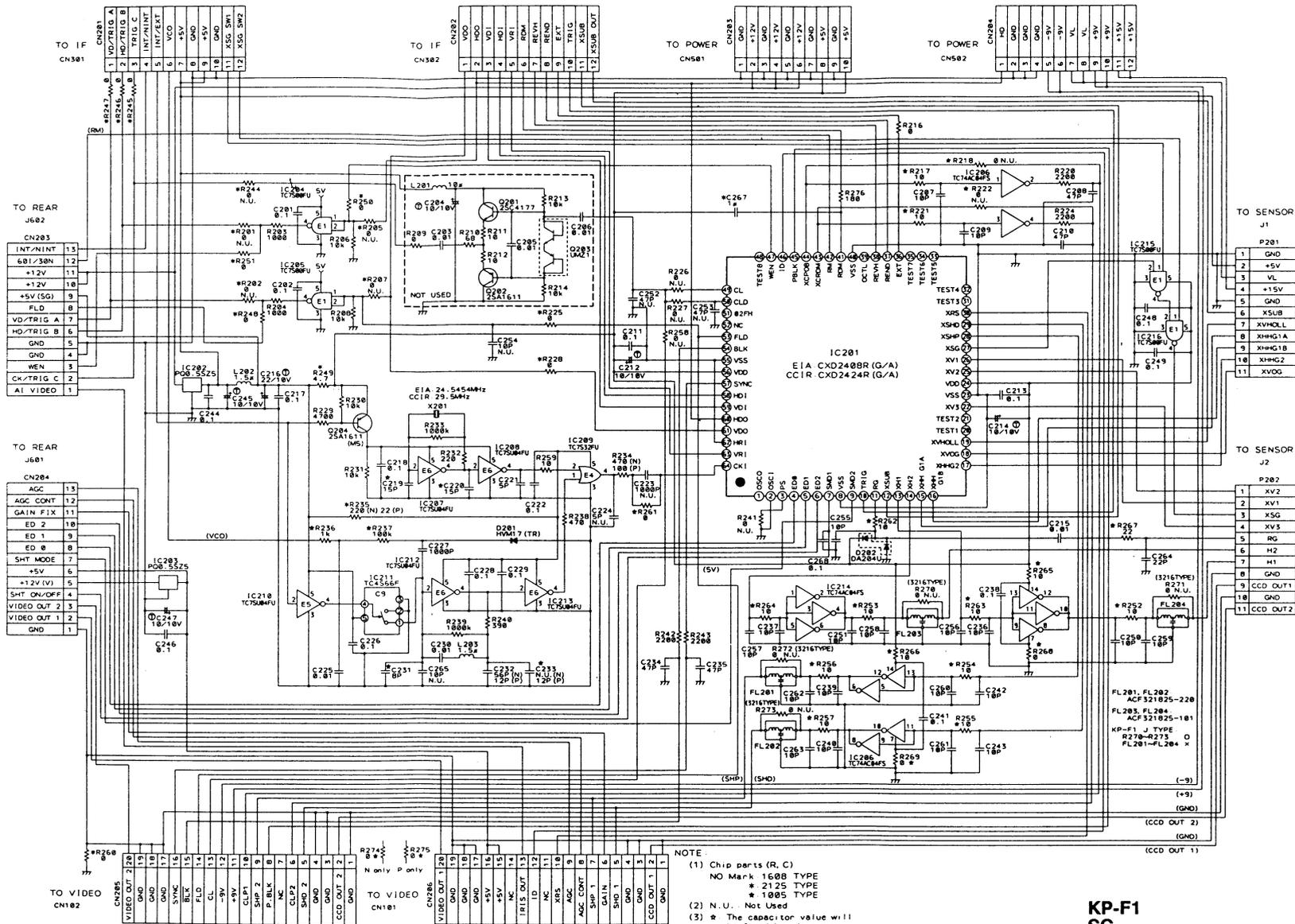

NOTE:
 (1) Chip parts (R, C)
 NO Mark 1608 TYPE
 * 2125 TYPE
 * 1005 TYPE
 (2) N.U. : Not Used
 (3) * The capacitor value will be fixed by adjustment.

**KP-F1
 SG
 SCHEMATIC DIAGRAM**

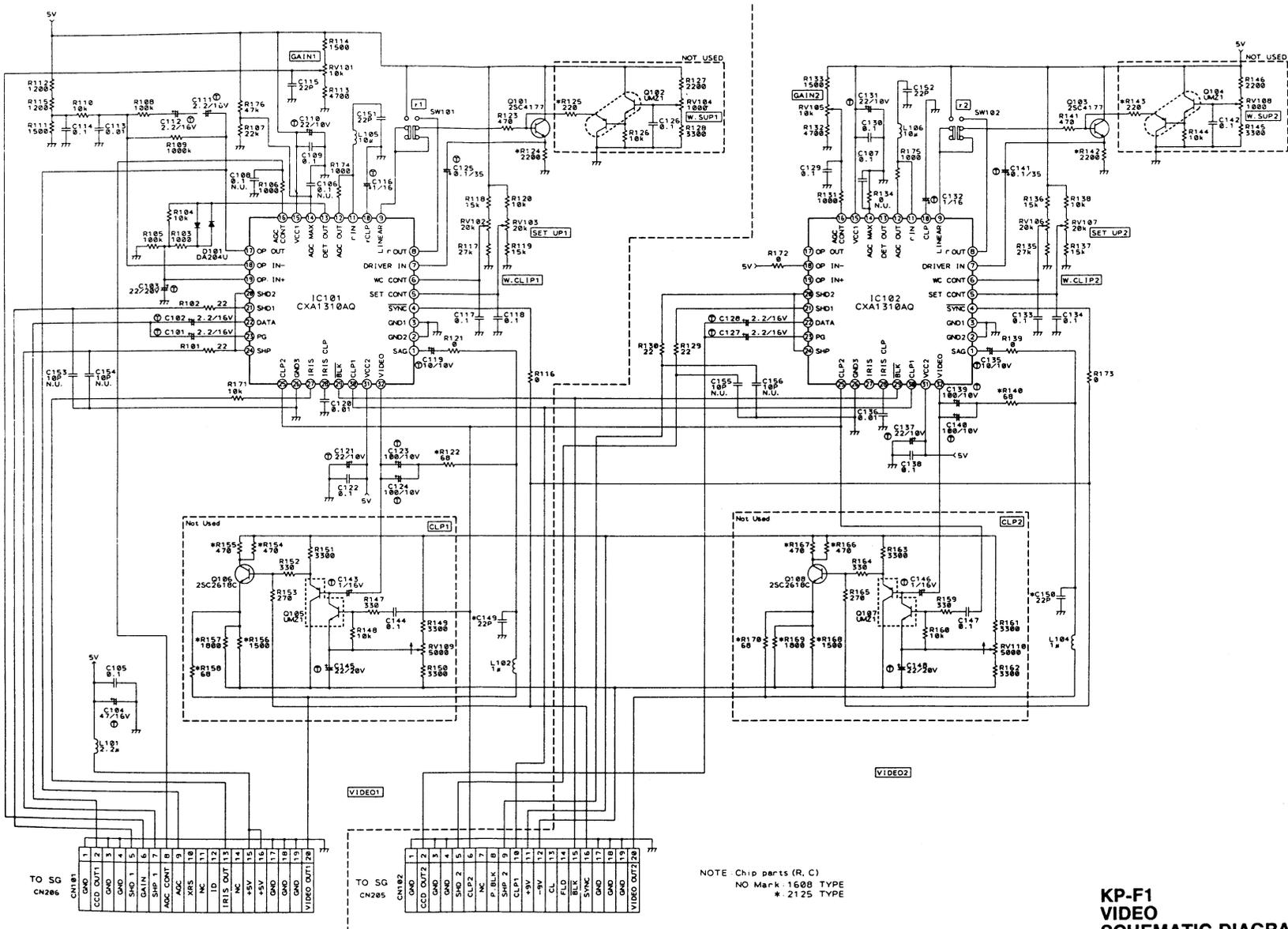

TO SG
CN206

CN181	+
CCD OUT1	2
GND	3
GND	4
SHO 1	5
GAIN	6
SH1	7
AGC CONT B	8
AGC	9
XRES	10
MC	11
TRIS OUT 1	12
MC	13
+5V	14
+5V	15
GND	16
GND	17
GND	18
GND	19
VIDEO OUT1	20

TO SG
CN205

CN182	+
CCD OUT2	2
GND	3
GND	4
SHO 2	5
CLP 2	6
MC	7
P.BLK	8
CLP 1	9
+5V	10
+5V	11
-5V	12
FLD	13
FLD	14
BLK	15
SYNC	16
GND	17
GND	18
GND	19
VIDEO OUT2	20

NOTE Chip parts (R, C)
NO Mark: 1500 TYPE
* 2125 TYPE

KP-F1 VIDEO SCHEMATIC DIAGRAM

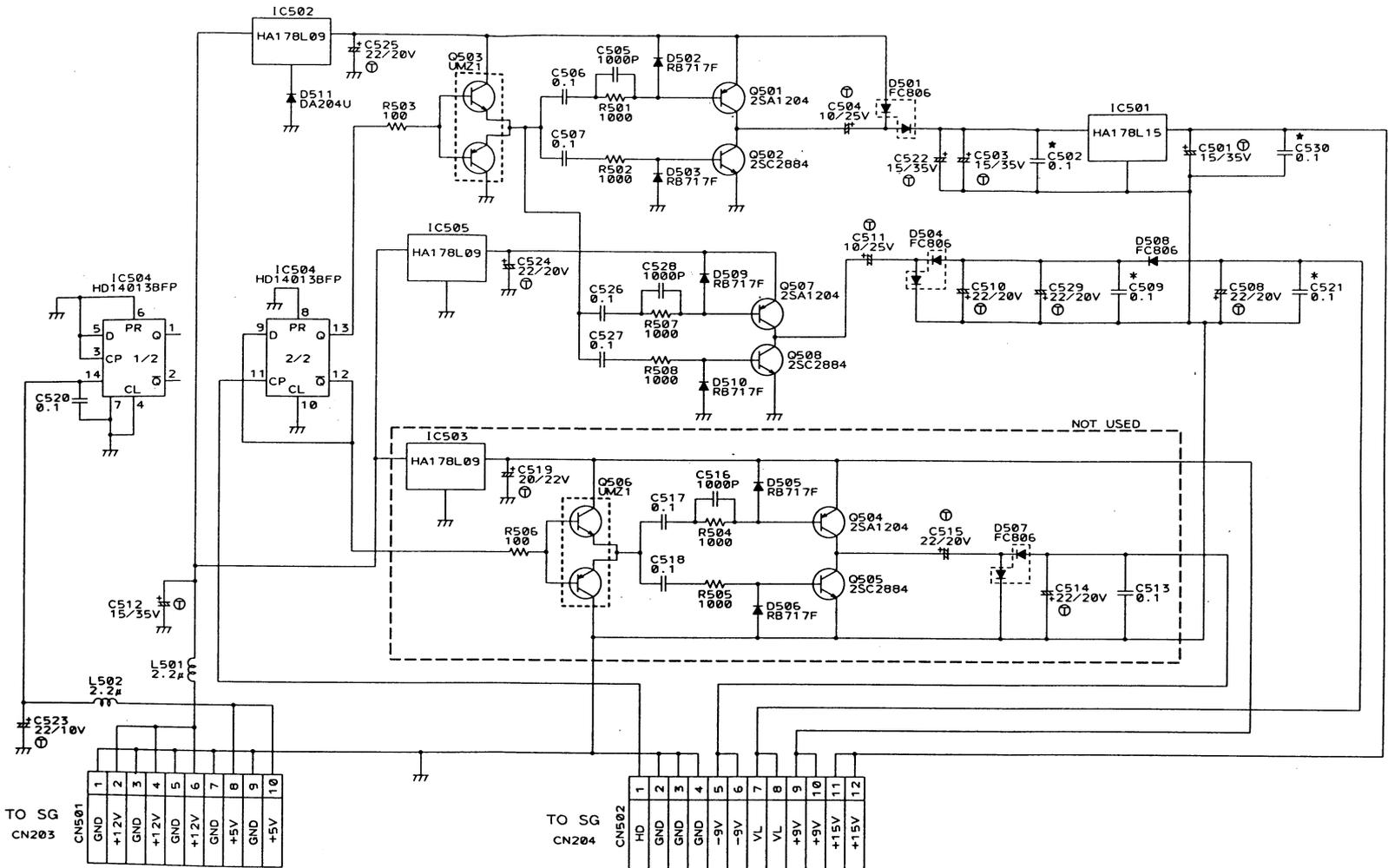

NOTE : Chip parts (R, C)

NO Mark : 1608 TYPE

* : 2125 TYPE

★ : 3216 TYPE

**KP-F1
POWER
SCHEMATIC DIAGRAM**

TO SG
P204

TO SG
P203

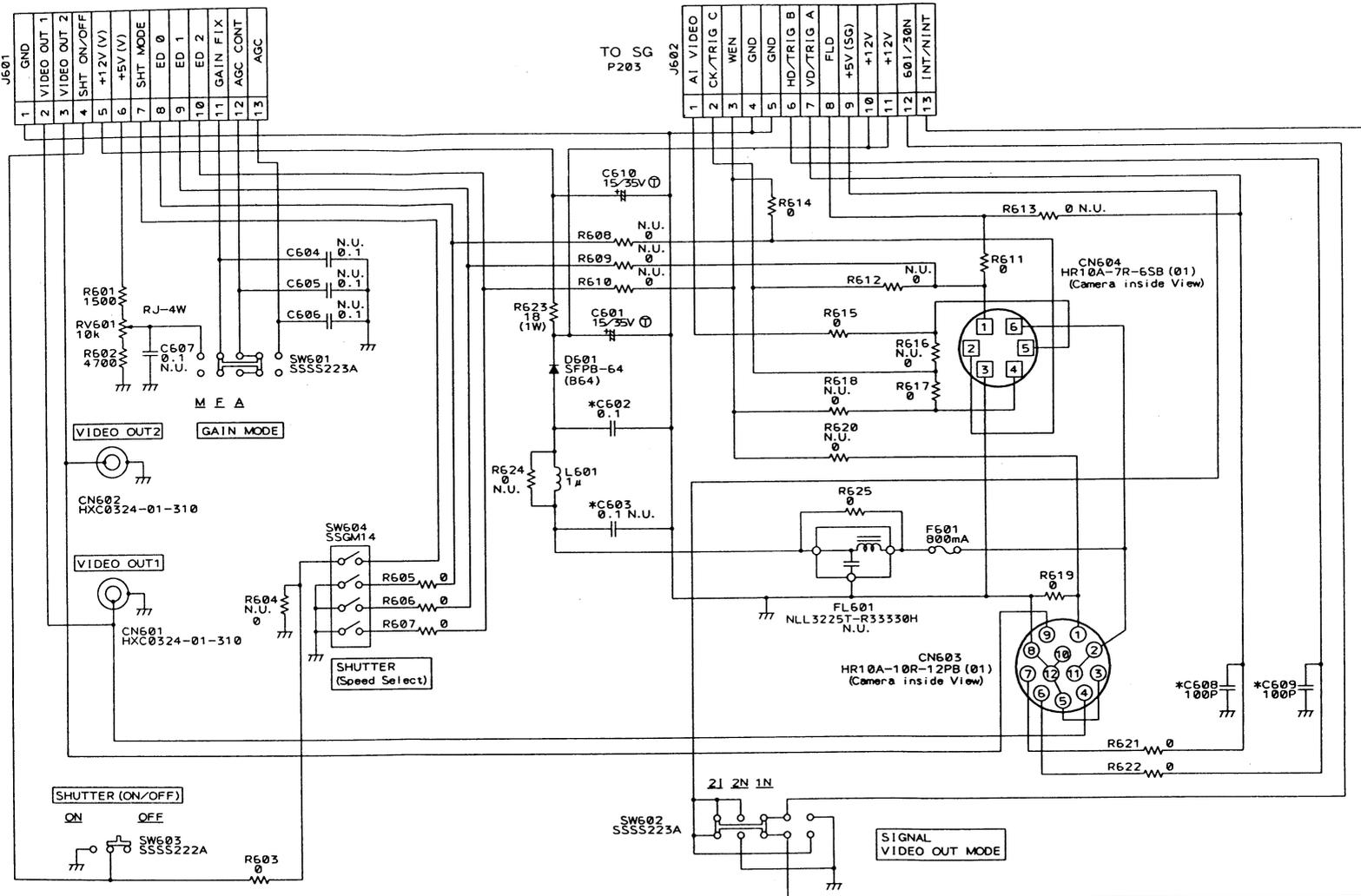

NOTE :

- (1) Chip parts (R, C)
NO Mark : 1608 TYPE
* : 2125 TYPE
- (2) N.U. : Not Used

**KP-F1
REAR
SCHEMATIC DIAGRAM**

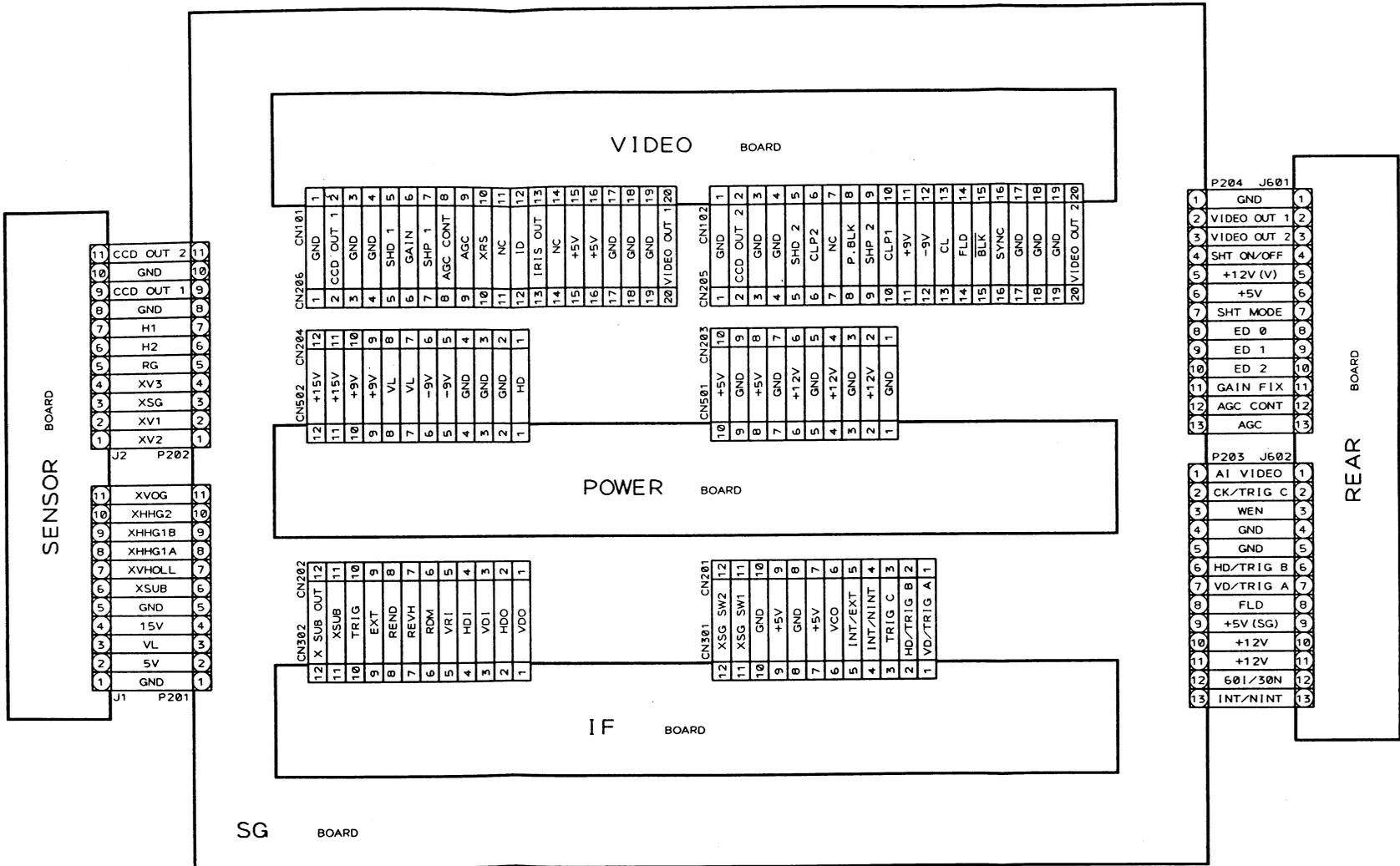

NOTE :

 DETACABLE

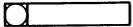
 UNDATAABLE

KP-F1
WIRING DIAGRAM

13. MECHANICAL PARTS LIST AND EXPLODED VIEW

SYMBOL	PARTS CODE	DESCRIPTION	Q'ty
1	4013686A	Mount cap	1
2	8469395A	Filter cover	1
G01	23X0119	SENS/SG unit assy (for EIA)	1
G01	23X0120	SENS/SG unit assy (for CCIR)	1
G02	23E0118	VIDEO unit assy	1
G03	23E0119	POWER unit assy	1
G04	23E0120	IF unit assy	1
G05	8616096LA	Front frame assy	1
G06	23X0121	Rear frame assy	1
G07	8616096LE	Bottom frame assy	1
G08	8616097LA	Top cover assy (for J)	1
G08	8616097LB	Top cover assy (for U)	1
G08	8616097LC	Top cover assy (for E/K)	1
101	8546538A	Screw W/SW SEMS M2×5 FE ZNP	3
102	XCA1809	Screw BIND M2×5 FE DNIP	3
103	XCA1912	Screw BIND M2.6×8 FE DNIP	3
104	8370588D	Screw PAN HD M2×3 FE	8

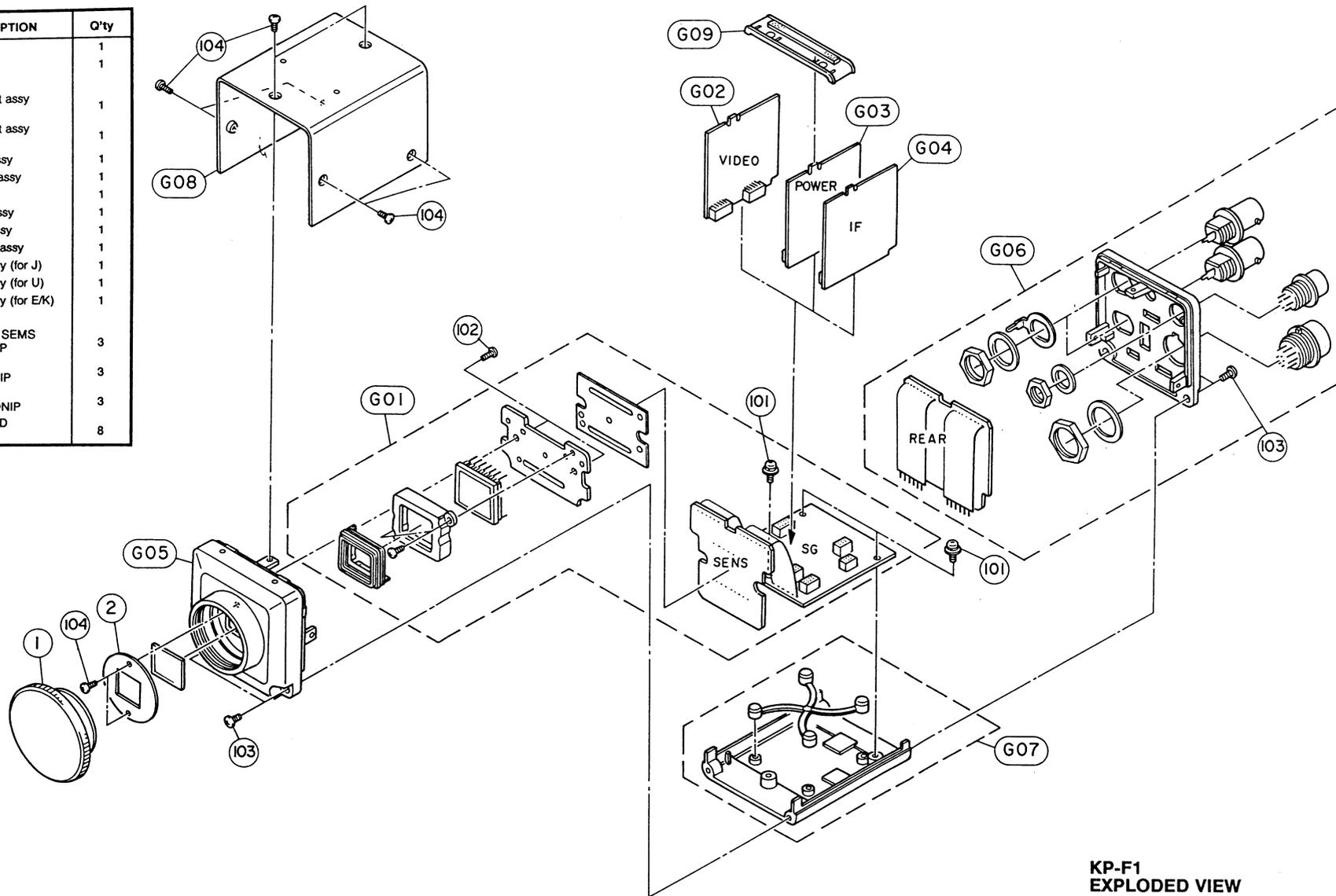

**KP-F1
EXPLODED VIEW**